

FREE STANDING WORK AREA CRANES

20', 25' & 30' SUPPORT CENTERS

- * Self-supported Work Area Bridge Crane Systems.
- * Steel Column spacing (SD) = 20'-0, 25'-0, or 30'-0
- * Systems include:
 - > Bridge
 - > Runways
 - > Festoon Cable Trolleys
 - > End Trucks
 - > Support Frames
 - > 4-Cond #14 Flat Cable
 - > Hoist-Trolley
 - > Hanger Assemblies
 - > Festoon Clamps
 - > Floor Anchor Bolts
 - > Splice Assemblies
 - > Festoon Stack-up Section
- * Bracing to building steel is not required. CraneVeyor free standing crane systems meet all Seismic Zone 4 requirements.

* Part Number Explanation:

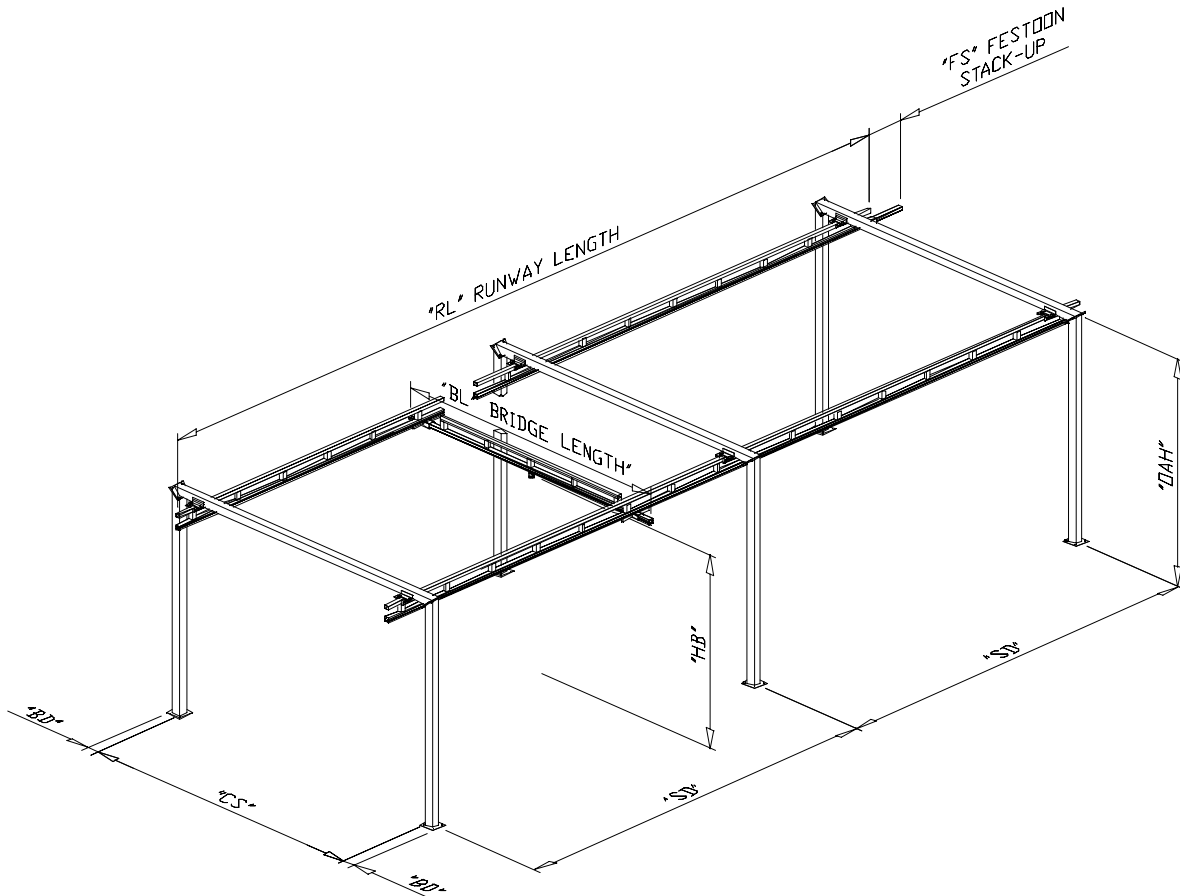
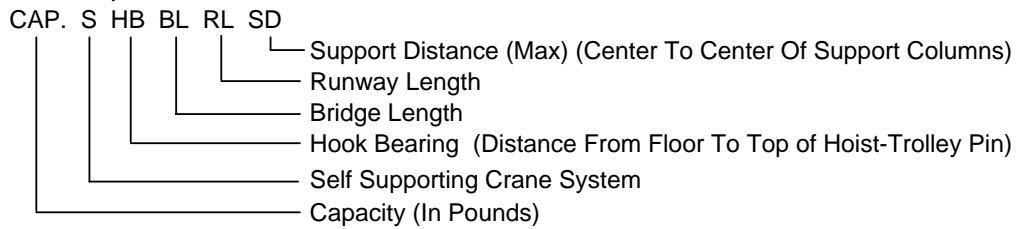

CraneVeyor Free Standing Crane Systems are based on using grout under the base plates for leveling. The standard Overall Height (OAH) dimension includes 1" from bottom of base plate to finished floor for leveling nuts and grout.